

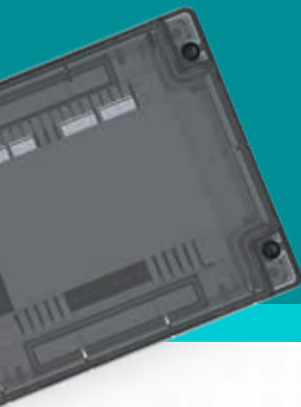

World Class Leaders in Fire Detection Since 1918



A Guide To

# BS5839-1:2017

Understanding the selection, spacing and siting of detectors

Welcome to  
**A Guide to BS5839 Part 1 : 2017**  
from  
**HOCHIKI EUROPE (UK) LTD**

This booklet is designed to provide essential information on key points from newest edition of the BS5839 Part 1 specifically identified as being important for the installer of fire detection products. It should never be utilised as any form of substitute for the standard itself.

**Remember, the correct positioning of detection devices\* and call points is essential to avoid unwanted alarm activations.**

Further detailed information can be acquired from the standard, contact BSI directly for your copy, or visit their website at [www.bsi-global.com](http://www.bsi-global.com).

Alternatively contact our Technical Support Department who will be pleased to help clarify any questions regarding the standard.

**+44 (0)1634 260133 - Option 2**  
**[psupport@hochikieurope.com](mailto:psupport@hochikieurope.com)**

**\*Note: The phrase “detection device” has been used throughout to represent both analogue sensors and conventional (non-addressable) detectors.**



Quality Certificate No.164QMS  
Assessed to ISO 9001  
Environmental Certificate No.164EMS  
Assessed to ISO 14001



Fire Alarm and Fire Detection systems are categorised in the following way:

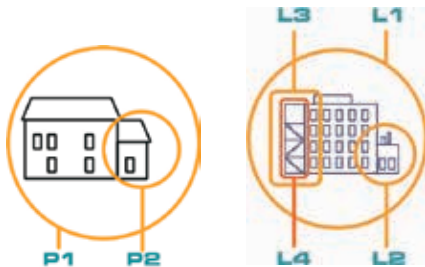

**P** = AFD\* designed to primarily protect Property

**P1** = AFD installed throughout all areas

**P2** = AFD installed only in specified areas



**L** = AFD designed to primarily protect Human Life

**L1** = AFD installed throughout all areas

**L2** = AFD installed in defined areas in addition to L3

**L3** = AFD installed in escape routes (as L4) and in rooms opening onto those routes this may include voids.

**L4** = AFD installed in escape routes comprising circulation areas and spaces such as corridors and stairways

**L5** = A non-prescriptive system in which the protected area(s) is designed and specified to satisfy a specific fire risk objective (other than that of L1 to L4)



**M** = System designed to be operated manually (no AFD) Categories L1, L2, L3 and L4 all include Manual Call Points. To add Manual Call Points to P1, P2 or L5, add/M e.g. P1/M

(\*AFD = Automatic Fire Detection)

## CONVENTIONAL vs ADDRESSABLE

**CONVENTIONAL** - A conventional fire detection system employs 'spurs' of detectors grouped into Zones. When a detector is in alarm/fault only the Zone is reported at the CIE

**ADDRESSABLE** - An addressable (intelligent) fire detection system employs a loop of sensors and other devices which are all individually addressed numerically. When a sensor is in alarm/fault the address of that device (and in most cases, a textual description) is reported at the CIE.

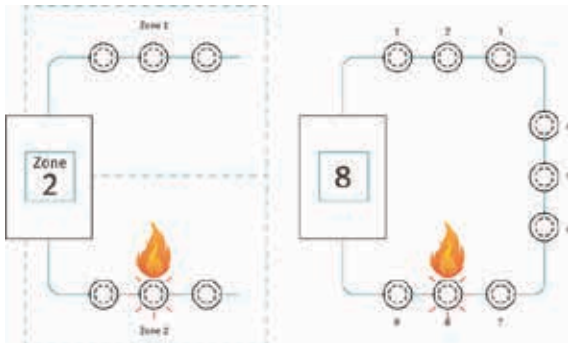

Where occupants of a building are going to need assistance from staff to evacuate the building (e.g. in residential care premises and hospitals), the fire detection and fire alarm system should be **ADDRESSABLE** if the building has facilities for **MORE THAN 10 PEOPLE** to sleep.



Up to 10 beds

**NON-ADDRESSABLE**

More than 10 beds  
**ADDRESSABLE**





Alarm device circuits should be arranged so that, in the event of a single fault, at least one sounder, sited within the vicinity of the CIE, will continue to operate .



Sufficient sounders, operating within the frequency range of **500Hz** to **1000Hz**, should be installed to ensure that a sound pressure of **65dB(A)** OR **5dB(A)** above a background noise (if lasting more than 30 seconds) at all accessible points with all doors closed. This may be reduced to **60dB(A)** in stairways or enclosures less than **60m<sup>2</sup>** excluding corridors.

## Visual Alarms Devices (VADs)

- ▶ EN54 Part 23 Specifies the Light Output required for VADs:
  - ▶ 0.4 lux (0.4 lumens/m<sup>2</sup>)
  - ▶ Not designed to wake sleeping people.
- ▶ Colour can be red or white light.
- ▶ The standard also defines three VAD Categories:
  - ▶ 'C' - Ceiling Mounted VADs
  - ▶ 'W' - Wall mounted VADs
  - ▶ 'O' - Open category devices

### Wall Mounted

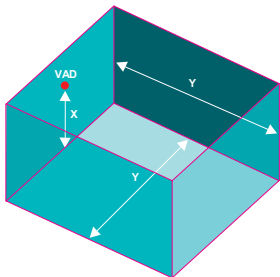

### Rating **W-X-Y**

**X** is the mounting height of the VAD has a minimum value of 2.4 metres.

**Y** is the length and width of VAD base

e.g **W-2.4-5**

2.4 metres is the mounting height  
5 metres is the base length and width

### Ceiling Mounted

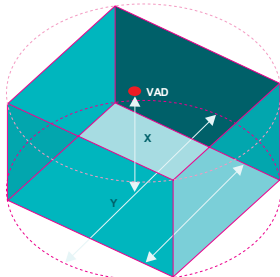

### Rating **C-X-Y**

**X** can be 3, 6 or 9 metres only.

**Y** is the diameter in metres

e.g **C-3-7.5**

3 metres is the mounting height  
7.5 metres is the effective diameter

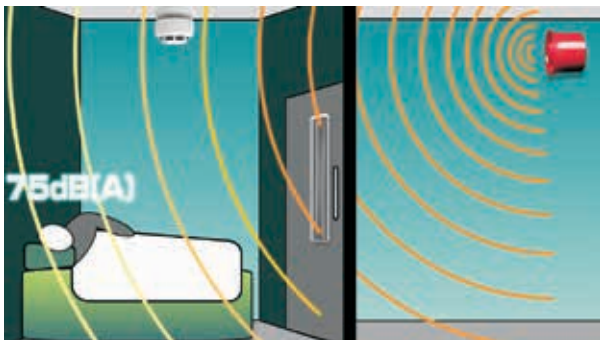

For areas where people are sleeping, sounder devices should produce a minimum of **75dB(A)** at the bed-head with all doors closed. This will probably require a sounder within the room.



A reduction in sound pressure of approximately **20dB(A)** may be expected through a normal door, and approximately **30dB(A)** through a fire door.

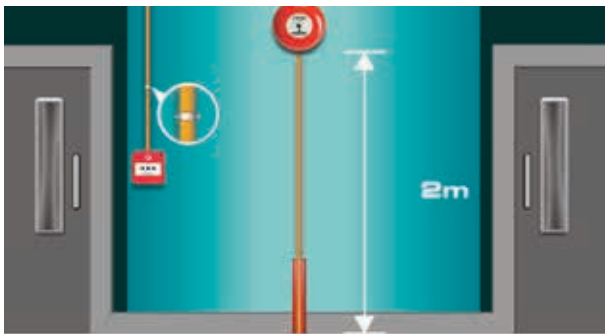

All fire alarm cables, below the height of **2m** from the finished floor level should be mechanically protected, unless enhanced. If a cable passes through a floor, sleeving up to 300mm minimum should be provided. Metal fixings should be used throughout.



Visual alarms devices (VADs) such as strobes and beacons may be ceiling or wall mounted, but for wall mounting the minimum of **2.1m** from finished floor levels applies. It is advisable to fit synchronised VADs, otherwise unsynchronised VADs may be perceived as an increased flash rate and may induce a photosensitive epileptic seizure.



It is important to ensure that a suitable, **correctly orientated zone plan** is provided adjacent to all CIE (including any repeat control and/or indicating equipment), unless the CIE incorporates a suitable display (e.g. an illuminated mimic diagram).



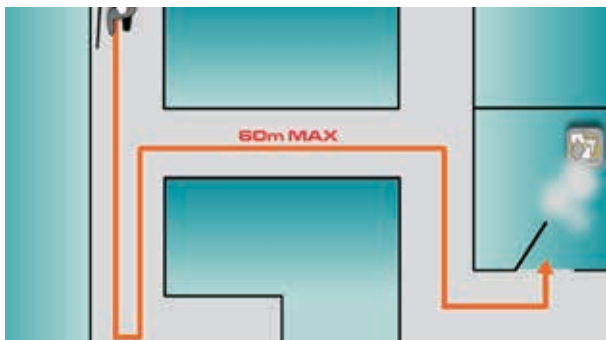

A person searching a Conventional Zone for a fire should not have to travel more than **60m** from the point of entry into the Zone to identify evidence of a fire.

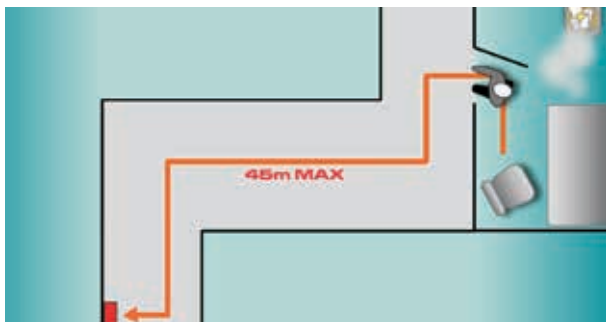

No one should have to travel more than **45m** to reach the nearest Manual Call Point, or **25m** in areas where a higher fire hazard is recognised, for example kitchens, paint booths etc. The **25m** travel distance would also apply where a person in a wheelchair would be expected to operate a Manual Call Point.

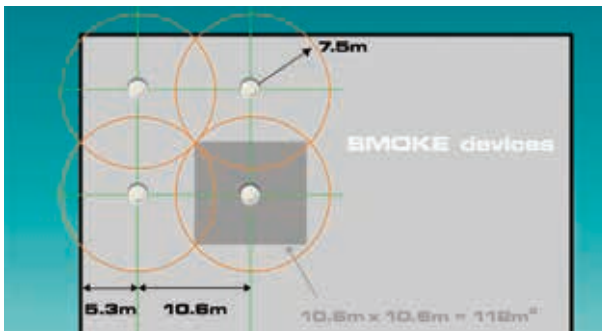

Smoke detection devices have an individual coverage of **7.5m** radius. However these radii must overlap to ensure there are no “blind spots”. Therefore the individual coverage can be represented by a square measuring **10.6m x 10.6m** giving an area coverage of per device (usually approximated to **100m<sup>2</sup>**).

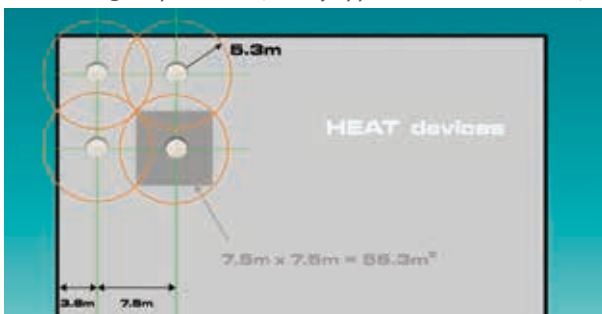

Heat detection devices have an individual coverage of **5.3m** radius. However these radii must overlap to ensure there are no “blind spots”. Therefore the individual coverage can be represented by a square measuring **7.5m x 7.5m** giving an area coverage of **56.25m<sup>2</sup>** per device (usually approximated to **50m<sup>2</sup>**).

*Note: If multi-sensors are used, space as heat sensors if selected as heat-only in the panel programming. Refer to Annex E of BS5839 for correct sensor selection, including multi-sensors.*

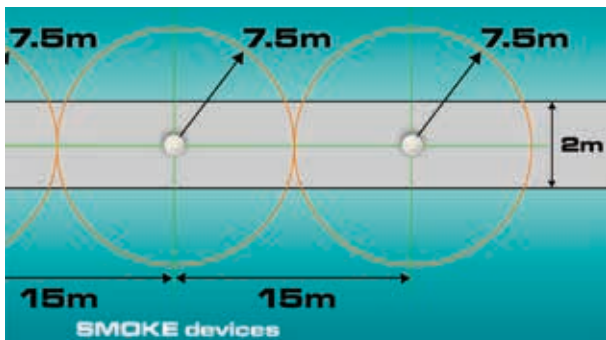

In corridors less than **2m** wide the horizontal spacing of smoke detectors may be increased, the areas of coverage need not overlap as in the case of a room. Note that in corridors CO sensors can only be used in-conjunction with smoke sensors.

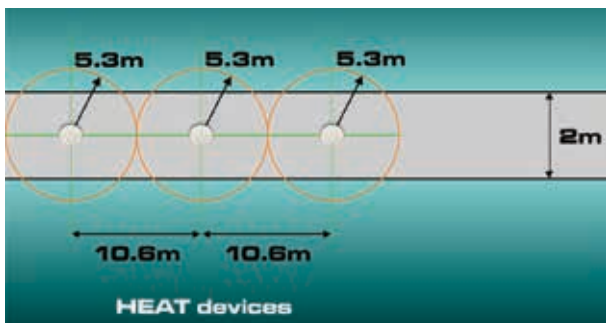

The standard does not recommend using heat sensors in escape routes, unless covered by a variation. In corridors less than **2m** wide the horizontal spacing of heat detectors may be increased, the areas of coverage need not overlap as in the case of a room. If a corridor is deemed part of an escape route heat detectors should not be installed due to the possibility of smoke hazard.



Ceiling obstructions, if deeper than **10%** of the ceiling height, or floor mounted obstructions (e.g. partitions) where the top is less than **300mm** from ceiling should be treated as walls. No detection device should be mounted within **500mm** of any wall or obstruction treated as a wall.

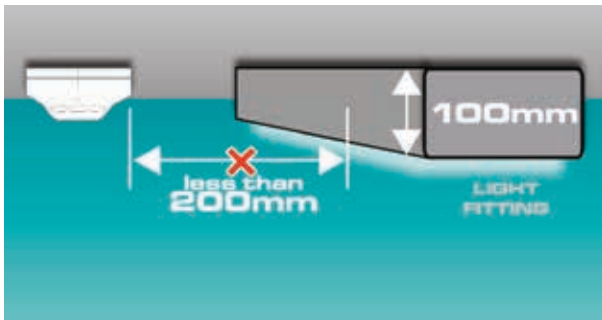

Detection devices should not be mounted closer than twice the depth of any obstruction less than **250mm** and less than **10%** of the ceiling height.

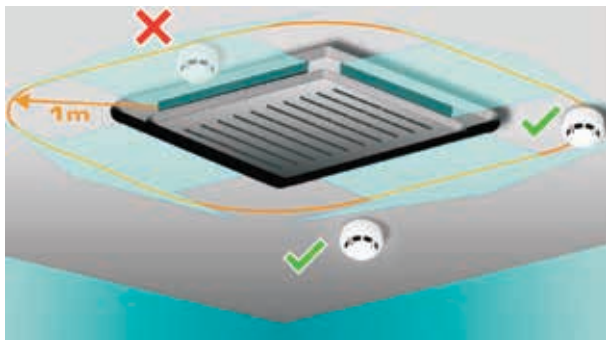

Detection devices should not be sited within **1m** from air inlets or forced ventilation systems (air-conditioning).

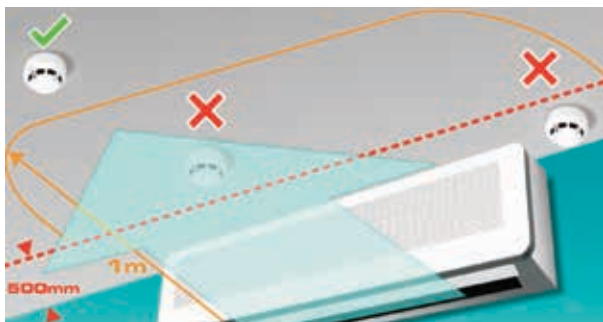



If the system category requires detection in any area, which has a void deeper than **800mm** but less than **1500mm** depth, detection should be provided in the void. All such detection should be sited in the top **10%** or **125mm** of void depth (whichever is the greater).



Voids deeper than **1500mm** may be treated as a room when siting detectors below the ceiling - **150mm** for heat and **600mm** for smoke.

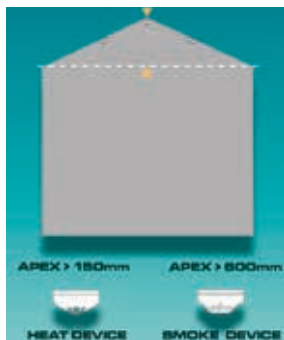
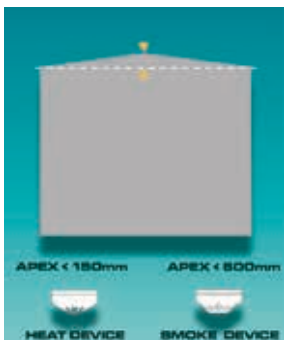

For ceilings that feature an apex: as long as the height difference between the apex and the height of the eaves is less than **150mm** for Heat detectors or less than **600mm** for Smoke detectors then these can be treated the same as flat ceilings. For higher apices, a device should be installed at or near the apex. The radius of cover for this detector only may be increased by 1% for each degree of roof angle, up to a maximum of 25%.

Detector Type	General max height	10% of area max height
Heat, fixed	7.5m	10.5m
Heat, RoR	9.0m	10.5m
Smoke, CO	10.5m	12.5m
OBSD, normal	25.0m	28.0m*
OBSD, enhanced	40.0m*	43.0m*
ASD, normal	10.5m	12.5m
ASD, enhanced	12.0m	14.0m
ASD, very high	15.0m	18.0m

\* Seek advice from the manufacturer/supplier

Limits of Ceiling Heights. For special ceiling height circumstances always refer to the complete standard.



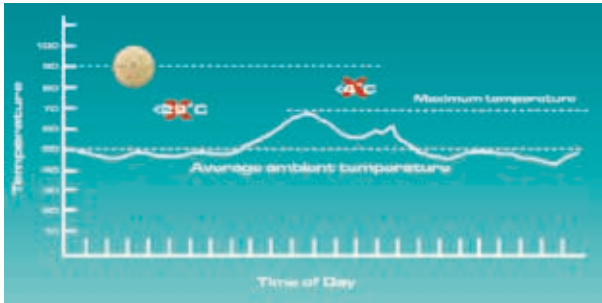

The minimum static response of heat devices should not be less than **29°C** above the average ambient temperature, or less than **4°C** above the highest temperature the device can be expected to experience.

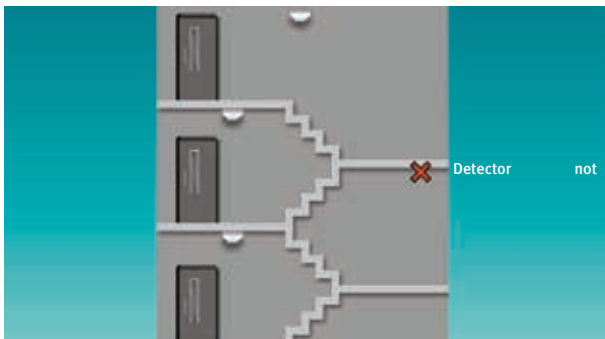

Enclosed stairways should have a detector at the top and at each main landing.

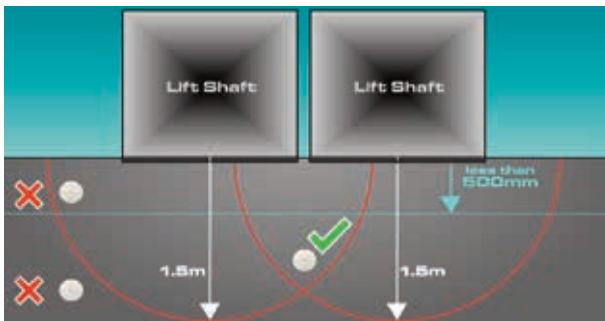

Other than in Categories L4, L5 and P2 (see page 3) any vertical flue-like structure (lift shafts, open risers etc) which penetrates one or more ceilings should have a detection device mounted at the top in the vertical structure and at each level, including the top floor, in the accommodation area, within about **1.5m** of any access hatch or door opening to the vertical structure. Example lift doors are shown.



Short circuit isolators (either on the loop or within the CIE) should be installed to limit the loss of fire cover caused by a single fault to **2000m<sup>2</sup>**. The loss of fire cover caused by two simultaneous faults should be limited to **10,000m<sup>2</sup>**. This will therefore restrict the cover provided by any analogue loop to **10,000m<sup>2</sup>** maximum.

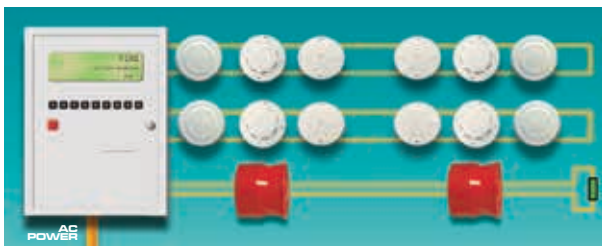

Cables used for the Critical Signal Path and the final LV (low voltage) mains supply to any fire detection equipment are now required to be fire resistant and coloured externally in a single, common colour (red is preferred). The LV supply to all parts of the system should be provided with a double pole, lockable isolation device for the safety of the maintainer. Non-critical cabling may still be non-fire resistant, for example door retainer circuitry which may fail to safe.



Manual Call Points should be positioned **1.4m (+/- 300mm)** from finished floor level and if sited below **1.1m** a variation will be required. They may be semi-recessed if readily visible but if required to be seen from the side (for example, in a corridor) they should be **15mm** proud of the wall.

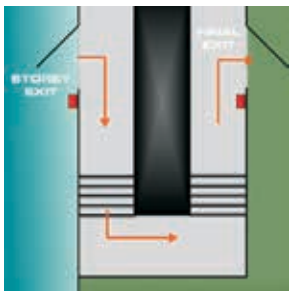

Manual Call Points should:

- ▶ Be positioned at all storey exits and arranged to display, at the CIE, as being within the storey zone or accommodation zone, not the stairway zone.
- ▶ Be positioned at all final exits to open air and arranged to display, at the CIE, as being within the stairway zone.

## CALL POINT COVERS RECOMMENDED

All call points should be installed with a call point cover. The standard does not specify whether existing installations should be updated to include call point covers, however if an existing installation doesn't have call point covers and the risk assessment indicates they are not required, it would be best practice to record this as a variation in the fire detection log book.



Product displayed: PS200 cover fitted to the HCP-E(SCI) manual call point

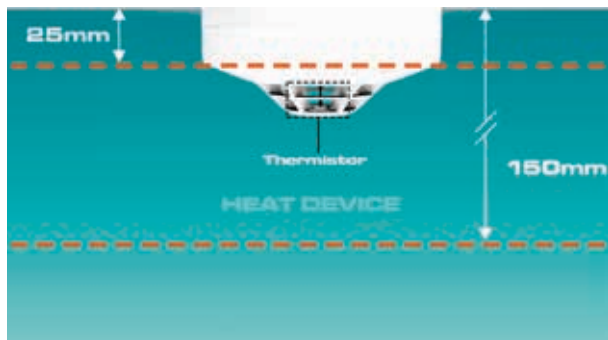

The sensing element of a Heat detection device (thermistor) should not be less than **25mm** below the ceiling, and not greater than **150mm** below the ceiling.



The sensing element of a Smoke detection device (photoelectric chamber) should not be less than **25mm** below the ceiling, and not greater than **600mm** below the ceiling.

## DEFINITION OF A MULTI-SENSOR

Clause 3.40 defines a multi-sensor as, a “fire detector that monitors more than one physical and/ or chemical phenomenon associated with fire”.

BS 5839-1 2017 acknowledges that a multi-sensor could be; optical and heat, CO and heat, or smoke, heat and CO. The standard does however accept that a multi-sensor can also be used in a single sensor state. Whichever state the multi-sensor is being used in, the detector should meet the performance requirements of the appropriate part of BS EN 54.



Product displayed (left to right) - ACC-EN(WHT) Multi Sensor & ACD-EN(WHT) CO Multi Sensor

## **VIDEO FIRE DETECTION**

Video fire detection is now a recognised specialised fire detection technique, specifically for L5 and P2 consultant specified categories.

## **ANNEXE E**

Annexe E details the correct procedure for the selection of detector type, to reduce false alarms.

In a further attempt to reduce false alarms, Annexe E also recommends;

- ▶ The use of staff alarms to validate a fire alarm and avoid unnecessary mass evacuation and/or fire service call outs.
- ▶ Linking fire alarm systems to security alarms to ensure that the responsible person is notified, even when there is no-one in the office at night. However, it is important to ensure that the battery capacity of the security alarm is equal to that of the fire alarm.
- ▶ The deactivation of the connection to the alarm receiving centre (ARC) during maintenance to avoid unnecessary call outs.



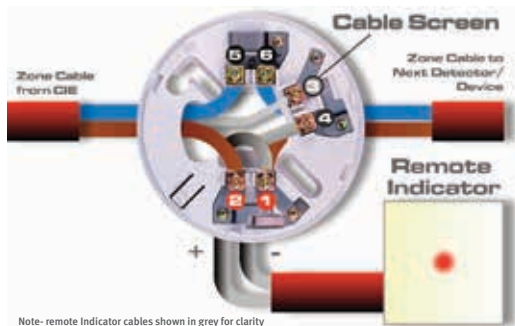

The **YBN-R/6** standard **conventional** base from the Hochiki range should be wired as shown above.

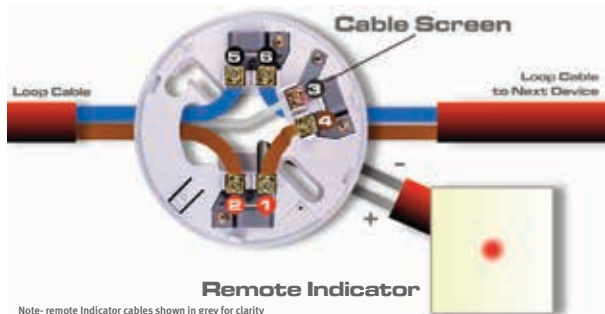

The **YBN-R/3** standard **analogue** base from the Hochiki range should be wired as shown above. All remote indicators should be tested at least once per year and should be wired with the same grade of cable as the detection circuits (Enhanced/ Standard). This can be reduced to **1mm<sup>2</sup>** to facilitate installation.

Hochiki Europe product ranges:

## ESP<sup>intelligent</sup>

Hochiki's comprehensive ESP Analogue Addressable range is suitable for even the most demanding applications and incorporates high performance sensors, a wide selection of input and output modules and ancillaries. All products use Hochiki's high integrity communications link 'ESP' (Enhanced Systems Protocol) that's at the heart of the ESP range.

## CDX<sup>conventional</sup>

Hochiki's CDX range offers one of the most extensive product portfolios available, providing solutions for most conventional fire detection applications as well as security systems, due to its wide operating voltage range (9.5-30V).

## FIREscape<sup>®</sup>

FIREscape is a unique, highly cost effective and environmentally friendly emergency lighting system based on LED technology and is the UK's first to be fully intelligent.

## FIREwave<sup>®</sup>

The FIREwave intelligent wireless range consists of sensors, modules, call points and audio/visual equipment which are fully intelligent with high reliability and sensitivity. Makes additions to existing wired systems easy and cost effective

## FIRElink<sup>®</sup>

The FIRElink range of high sensitivity air sampling equipment consists of detectors and sampling pipe accessories to the very highest levels of sensitivity in environments such as computer areas and clean rooms.



Your Safety, Our Technology



## HOCHIKI EUROPE (UK) LIMITED

Grosvenor Road, Gillingham Business Park,  
Gillingham, Kent, ME8 0SA, United Kingdom

Telephone: +44 (0)1634 260133

Facsimile: +44 (0)1634 260132

[info@hochikieurope.com](mailto:info@hochikieurope.com)

[www.hochikieurope.com](http://www.hochikieurope.com)

ISS18 | MAR18

