



# PHOTOELECTRIC REFLECTIVE BEAM DETECTOR MODEL SRA-ET

Mounting Guidelines

## Siting

Select a suitable position for the installation of both SRA-ET and reflector, such that there are no visible obstructions between them. Remember that the beam detector works on the principle of reduction of light between the SRA-ET and reflector. If there is any possibility of an object remaining within the beam for a few seconds then the siting of the detector is unsuitable.

For mounting either the SRA-ET or reflector it is important to establish that the mounting place such as the wall is solid and that the beam detector alignment will be rigid. The wall may appear to be solid, but may be subject to twisting or other changes when the temperature outside the building varies greatly during one day, for instance on cold, frosty days. The installer must ensure that the beam will not be subject to misalignment due to changes in the building itself.

The spacing and siting in specific types of locations is covered in section 7.

The beam detector must not be installed in the following locations: -

- Where the ceiling height is greater than 40m
- A roof top or place where open air circulates
- Where the distance between top and bottom of the space is less than 0.5m
- Where objects such as ceiling beams or girders are within 75cm of the beam axis
- In locations where a large amount of dust, fine powder or water vapour is present
- In locations such as kitchens where smoke occurs normally
- In locations which are exposed to extremely high temperatures
- Where access to the beam detector is impossible for maintenance purposes
- Where the rigid fixing of either the SRA-ET or reflector is impossible
- Where access to the beam detector to align and set is impossible
- Where there is not a clear line of site between the Receiver and Reflector/Emitter

NOTE: The SRA-ET is not solar blind, therefore the SRA-ET or reflector should not be installed where they can be subjected to direct or reflected sunlight, i.e. via adjacent walls and reflective surfaces. It is recommended that in these locations or where the beam detector may be surrounded by glass, the SPB-ET should be fitted.

## Installation

Please check that the beam detector contains the following components so installation can be carried out.

- 1 SRA-ET
- 1 Reflector (**enclosed in packaging - do not discard**)
- 1 Mask
- 1 Installation manual
- 2 Fixing screws
- 1 SRA-ET mounting plate (termination module PCB on the back)

The termination module is designed to facilitate the installation of the SRA-ET beam detector to fire cables using a standard surface/flush dual gang installation box or the Hochiki SRA-ET Back Box. The module also provides three types of fault monitoring configurations, simple beam reset and remote fire indication.

## Opening the Detector Cover

Removal of the detector can be achieved by unscrewing the outer cover locking screw and pulling the cover forward and then lifting the cover off of the locating slots at the top of the fixing plate, the cover is then retained by an anti-drop cable. The fixing plate screws should then be loosened and the beam assembly can then be removed.

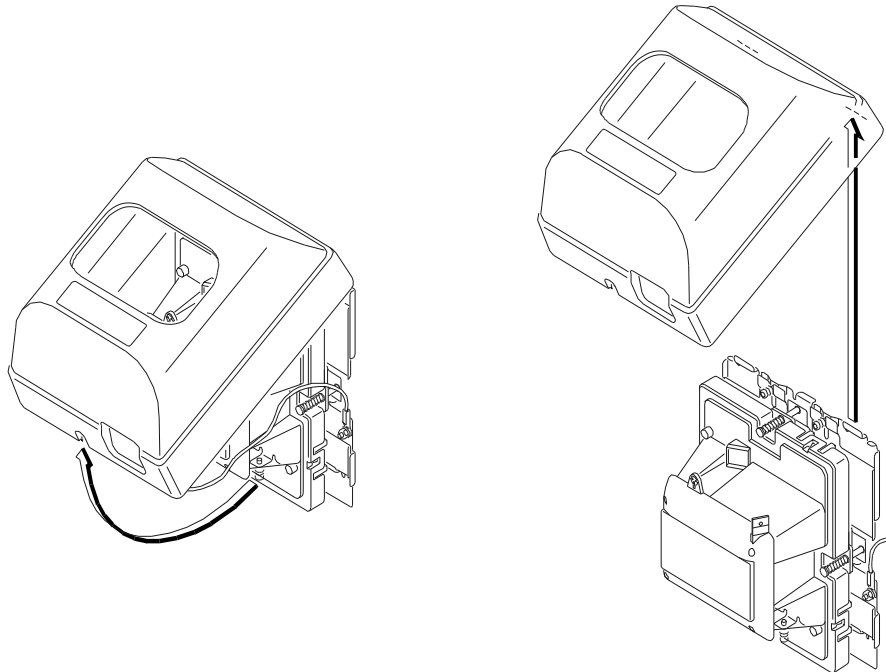

Fig 1 opening the detector housing

## Field Wiring & Line Continuity

The connection of this unit requires the use of a dual gang installation box, either flush mount or surface mount or the Hochiki SRA-ET Back Box. Suggested types are MK897 ALM surface mount, MK862 ZIC flush mount, but any equivalent type is usable providing that it has a minimum depth of 25mm. This item should be firmly fixed to the wall or other suitable mounting point first. With reference to the wiring diagrams shown in Figs 2 & 3 ensure that the field wiring is terminated into the dual gang installation box.

The Termination Module can be configured to provide correct operation for three different types of zone fault indication which provide the same fault detection functions as Hochiki's conventional detector bases when the detector heads are removed. The configuration is achieved using jumpers at the top of the termination PCB (see Fig 3) and the selection should be made according to the type of fire alarm control panel being used. If the SRA-ET is being used with a Zone Module then the jumpers need to be set to the normal mode.

- Normal:-** No line continuity option (zone is open circuit during fault).  
Jumpers LK1, LK4 & LK6 ARE MADE, all other jumpers are removed.
- Zener:-** Line continuity using a Zener clamp (produces detector removal fault at the control panel).  
Jumpers LK2 & LK5 ARE MADE, all other jumpers are removed.
- Schottky:-** Line continuity using a Schottky diode (produces detector removal fault at the control panel). Jumpers LK1, LK3, LK4 & LK6 ARE MADE, all other jumpers are removed.

**Note:** The Termination Module is factory configured for Schottky diode line continuity. If in doubt check the correct line continuity for the control panel.

**Warning:** When the Zener option is used it must be connected to a control panel, which is able to use this type of option. If connected either to an unsuitable panel or a 24V-power supply the interface could be damaged due to over-current.

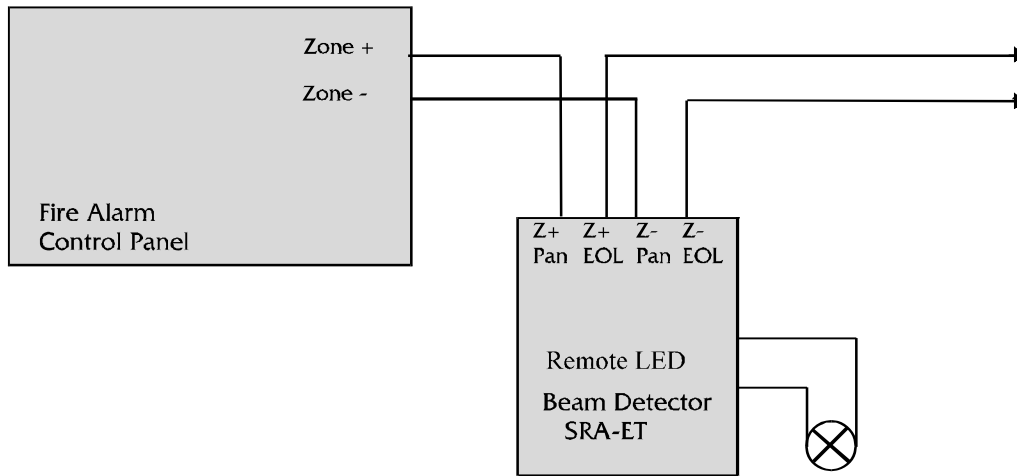

Fig 2 Termination module wiring diagram

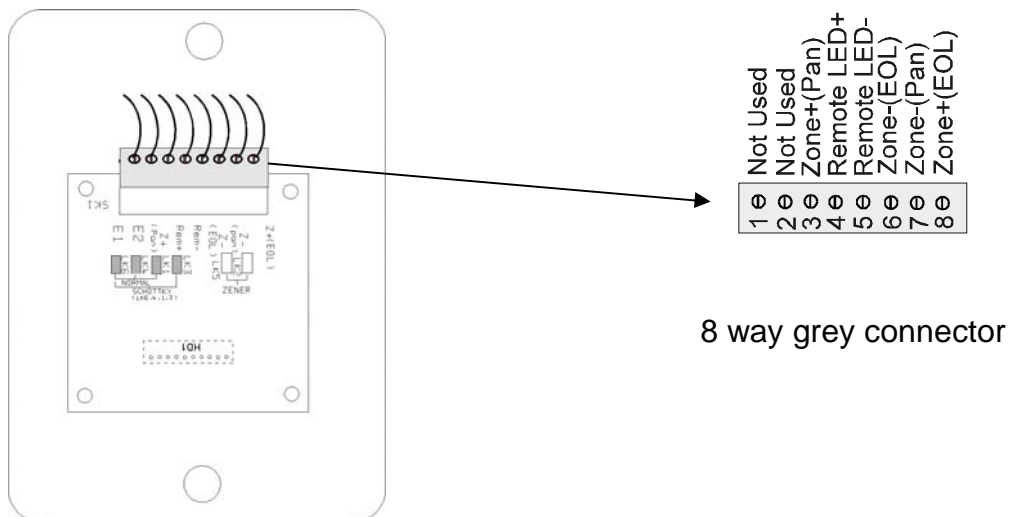

Fig 3

Unplug the 8 way grey connector from the end of the Termination PCB. Install the wires into the correct position and secure by the terminal screw (see Fig 3).

Ensure the grey connector is facing upwards and that the cables are insulated and neatly located into the base of the installation box. Plug the grey connector back into the PCB then connect the pre-wired ribbon cable assembly to the socket on the back plate, the back plate should then be screwed to the back box.

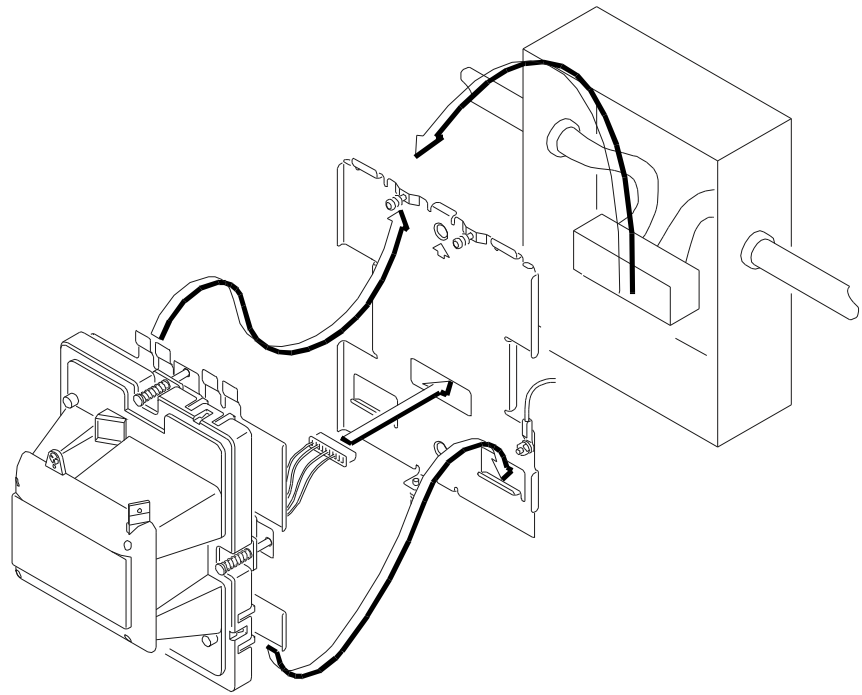

Fig 4 Termination Module Assembly

Fix the beam assembly to this by fitting the locating slots under the fixing screws and pushing the beam up until the locating tabs can be dropped into the back plate. The top fixing screws should then be tightened, and the cover fitted to the beam detector once the adjustment and calibration procedure has been completed - see "Adjustment & Calibration Procedure" on page 6.

**Reflector - Installation Procedure**

***Reflector to wall mounting:***

The reflector should be mounted using the 5mm fixing holes onto a flat surface with suitable screws, care should be taken not to over tighten these screws as this could damage or distort the reflector.

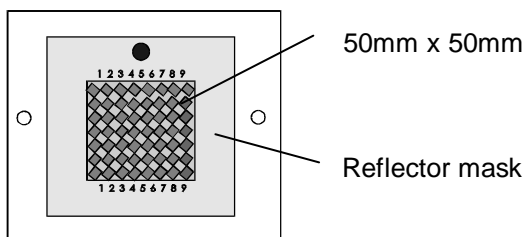

Fig 5

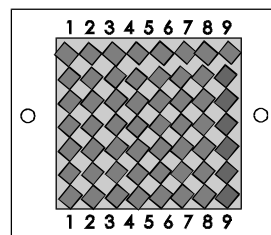
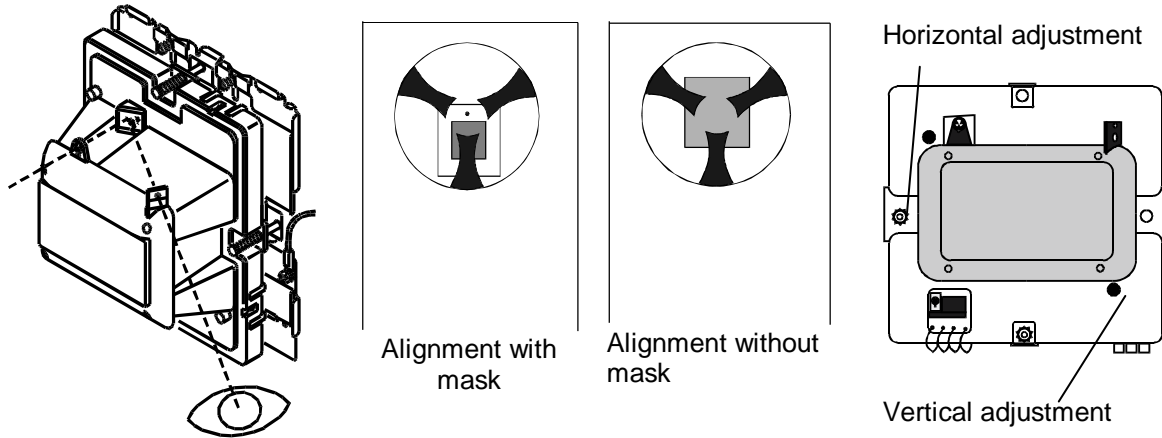

Fig 6

If the SRA-ET is being used over a distance of 5m-15m then the mask should be fitted to the reflector (Fig 5). From distances of 15m-30m then the mask must not be fitted to the reflector (Fig 6).

### Adjustment & Calibration Procedure

The adjustment procedure should be carried out by powering up the SRA-ET and setting the switch to calibrate; at this time the yellow LED will start to flash. Then, using the sight holes and alignment adjustment screws, the detector should be adjusted so the reflector can be seen in the centre of the sight hole. If the reflector is being used with the mask then the detector must be adjusted until the black dot on the reflector is in the centre of the site hole.



When setting the SRA-ET up the set up switch must be set to calibrate and left in this position. Returning the switch to the up position will reset the calibration.

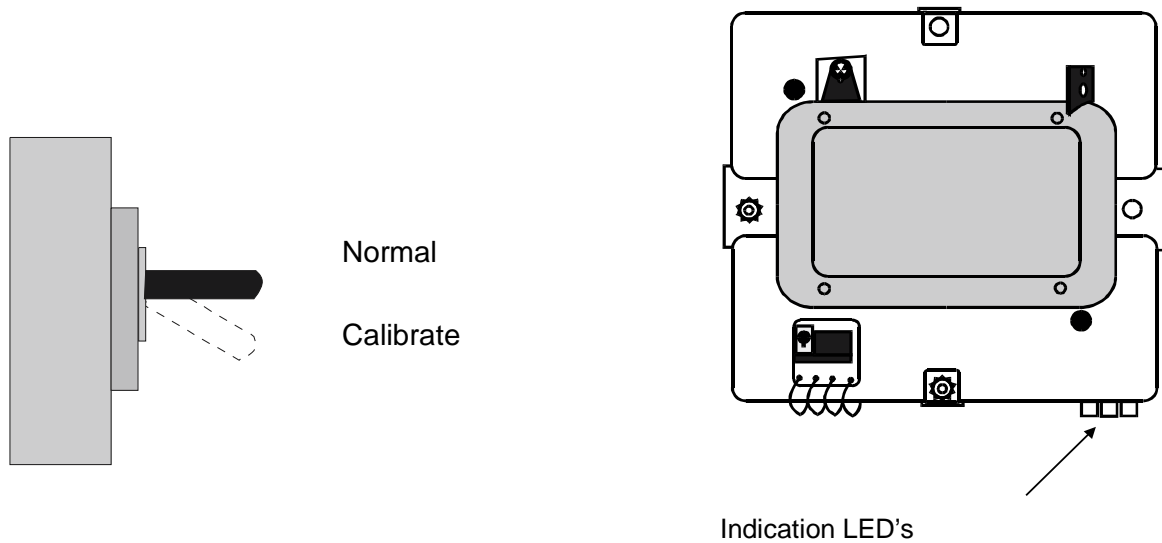

When the switch is in the Calibrate position the yellow and green operating LED's will be flashing this should last for one minute as the detector automatically adjusts. When this has been completed the yellow LED will extinguish and the green LED will continue to flash. If the adjustment isn't completed satisfactorily then the yellow LED will flash on its own. The cover should now be fitted and operation tests should now be carried out – see "Testing the SRA-ET" on page 7.

The SRA-ET has three LED's mounted underneath the unit, these are yellow, green and red and are illuminated depending on the current state of the SRA-ET. Please find below a table showing the various states of the SRA-ET and which LED's will be illuminated.

	LED 1	LED 2	LED 3
SRA-ET state	Green	Yellow	Red
Beam in set up mode	⊗	⊗	
Operating satisfactorily	⊗		
Beam in fault or calibration		⊗	
Beam in Fire	⊗ See Note 1	⊗ See Note 1	●

⊗ - LED Flashing (once every 3 secs) ● - LED illuminated

Note 1: The Green and Yellow LED may flash depending on the zone voltage in alarm

### Testing the SRA-ET

The reflector is marked with graduations between 1 and 9 which equates from 10% through to 90%. The SRA-ET can be tested by obscuring 60% of the reflector (see Fig 7) with a material that is non reflective and impervious to infra red light, it will then take 11 to 16 seconds for the beam detector to go into a fire condition. A non-operation test can be carried out by obscuring 40% of the reflector (see Fig 8).

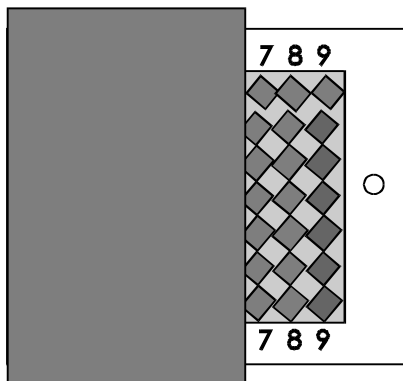

Fig 7 Operation Test

As shown above, up to graduation number 6 (60%) is obscured

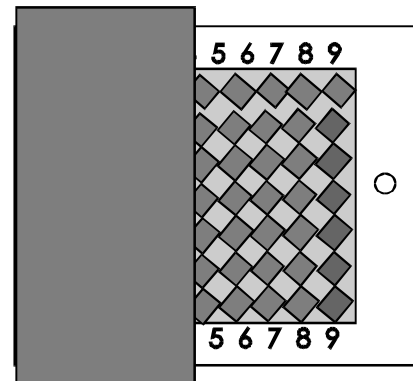

Fig 8 Non Operation Test

As shown above, up to graduation number 4 (40%) is obscured



Hochiki Europe (UK) Ltd  
 Grosvenor Road, Gillingham Business Park,  
 Gillingham, Kent, ME8 0SA, England  
 Telephone: +44(0)1634 260133 Facsimile:  
 +44(0)1634 260132  
 Email: sales@hochikieurope.com  
 Web: www.hochikieurope.com



0832-CPD-0454  
 10

EN54-12 Line type smoke detectors

Hochiki Europe (UK) Ltd. reserves the right to alter the specification of its products from time to time without notice. Although every effort has been made to ensure the accuracy of the information contained within this document it is not warranted or represented by Hochiki Europe (UK) Ltd. to be a complete and up-to-date description. Please check our web site for the latest version of this document.