

# HOCHIKI CHQ-Z(I.S.) I.S. COMPATIBLE DUAL ZONE MONITOR

## INSTALLATION INSTRUCTIONS



### Function

The CHQ-Z(I.S.) is an input monitoring device which connects to the Hochiki ESP analogue system. It is capable of monitoring two zones of intrinsically safe detectors through an intrinsically safe barrier. The unit also provides an auxiliary open collector transistor output, which can be used for local control via a suitable circuit if supported by the Control Panel. The module has been designed for easy installation and contains two connector blocks for termination of the field wiring.

### Specification

Order code	CHQ-Z(I.S.)* and CHQ-Z(I.S.)/OEM*	
Transmission method	Digital communication using ESP	
Loop:-Operating voltage	17 - 41 VDC	
Quiescent current	300µA	
Current consumption whilst polling	22 mA ± 20 %	
External Supply:-Operating voltage	20-28.8 VDC (24VDC nominal)	
Quiescent current	11 mA Min (plus detector load)	
Current consumption when in fire	100 mA (Both zones in fire)	
Auxiliary Open Collector output rating	24 VDC 30mA	
E.O.L device#	10kΩ resistor	
Zone resistance	50Ω (Max)	
Zone capacitance	0.3µF (Max)	
Compatible Base type	YBN-R/4 I.S.	
Colour and enclosure material	CHQ-Z(I.S.)	Grey, ABS (IP67 rated), c/w OEM module
	CHQ-Z(I.S.)/OEM	White, ABS

\* Fire alarm control panel compatibility required for these products.

# The EOL resistors supplied with the CHQ-Z(I.S.) comply with Hochiki's BASEEFA certification for conventional I.S. detectors. The user must check that any EOL resistors used comply with the certification requirements for the proposed installation.

### Connection Details

The CHQ-Z(I.S.) should be connected to the loop as shown below, the module does not support any line continuity options, therefore, if manual Call Points are to be interfaced to the CHQ-Z(I.S.) then these should be connected first. Detectors should be connected to the CHQ-Z(I.S.) in accordance with Hochiki's I.S. certification. **Note:- The CHQ-Z(I.S.) must be installed in the safe area along with the barrier.**

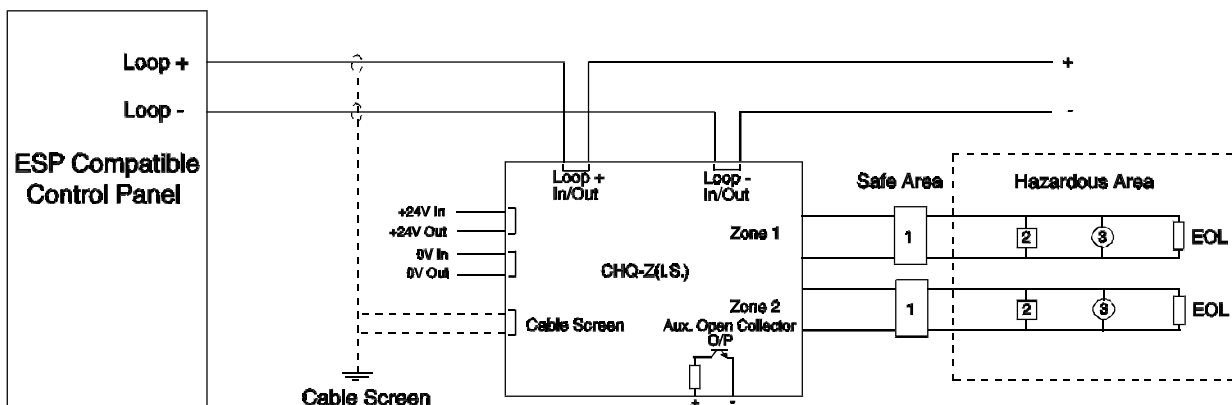

1 = I.S. BARRIER    2 = I.S. MANUAL CALL POINT    3 = I.S. DETECTOR    EOL = 10K RESISTOR

### Compatible Barrier Types

The CHQ-Z(I.S.) is capable of supporting the barrier types listed below:-

## Galvanic Isolators

MTL3043, 4061, 5061

KFDO-CS-Ex1.51, KFDO-CS-Ex2.51, KFDO-CS-Ex1.51P, KFDO-CS-Ex2.51P

## Zener Barriers

Any BASEEFA approved certified Zener barrier that has the following characteristics; 30VDC or less, 1W or less, 200 mA or less.

### Setting The Loop Address

- ❑ The address is set using the first 7 switches of the 8 bit DIL switch. The switch should be in the up position for ON and down for OFF.
- ❑ Set the switches as defined below for the required address.

### Installation

- ❑ Drill the cable entry holes in the enclosure as required before fitting the CHQ-Z(I.S.) module. Ensure glands conform to IP67, if such ingress protection is required.
- ❑ Mount enclosure as required, using the holes in the 4 corners which are located through the cover fixing point.
- ❑ Mount the CHQ-Z(I.S.) module inside the enclosure with the screws supplied.
- ❑ Terminate and connect field wiring as per wiring diagram
- ❑ Ensure the zones are terminated using the 10K? resistors (supplied), these must be connected to the last device on the zone .
- ❑ Set the ESP loop address ,using the 8-bit DIL switch-see opposite.
- ❑ Fix the label to the enclosure and note the units address.
- ❑ To comply with EMC regulations, the CHQ-Z(I.S.)/OEM must be fitted in a protective enclosure.
- ❑ The CHQ-Z(I.S.) must be installed in the safe area along with the barrier.
- ❑ Suitable anti-static precautions must be taken when handling this product.

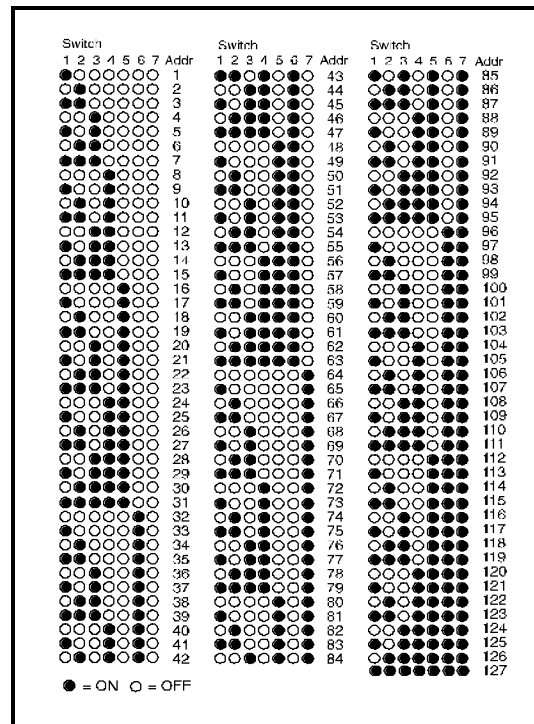

### Status LED

A red LED flashes each time the unit is polled by the fire alarm control panel or is continuously illuminated when either zone is active.



**Hochiki Europe (UK) Ltd**  
**Grosvenor Road, Gillingham Business Park,**  
**Gillingham, Kent, ME8 0SA, England**  
**Telephone: +44(0)1634 260133 Facsimile: +44(0)1634 260132**  
**Email: sales@hochikieurope.com**  
**Web: www.hochikieurope.com**

Hochiki Europe (UK) Ltd. reserves the right to alter the specification of its products from time to time without notice. Although every effort has been made to ensure the accuracy of the information contained within this document it is not warranted or represented by Hochiki Europe (UK) Ltd. to be a complete and up-to-date description. Please check our web site for the latest version of this document.