

INSTALLATION INSTRUCTIONS HUSH BUTTON

Products Covered: CHQ-HUSH



WARNING: To work correctly this device requires TWO addresses - please refer to the section 'SETTING THE CHQ-HUSH ADDRESS' on page 3.

Introduction

The CHQ-HUSH has been specifically designed to reduce the incidence of false alarms in 'houses of multiple occupation' by providing reliable, fully monitored fire detection, alarm and silencing facilities INSIDE each individual flat or apartment.

It can be looked upon as a miniature loop-powered single zone fire alarm controller that sits and is addressed on a Hochiki ESP analogue loop (see schematic below) with the ability to communicate its status back to the host panel. Typically one CHQ-HUSH is fitted in each dwelling complete with conventional detectors and conventional sounders to provide occupants with a simple means of invoking two types of 'hushed' period - as described on page 4.

By providing occupants with this level of control over their fire alarm systems, it helps reduce false alarms and prevent unnecessary building evacuations, system vandalism and the likelihood of a true alarm signal being ignored.

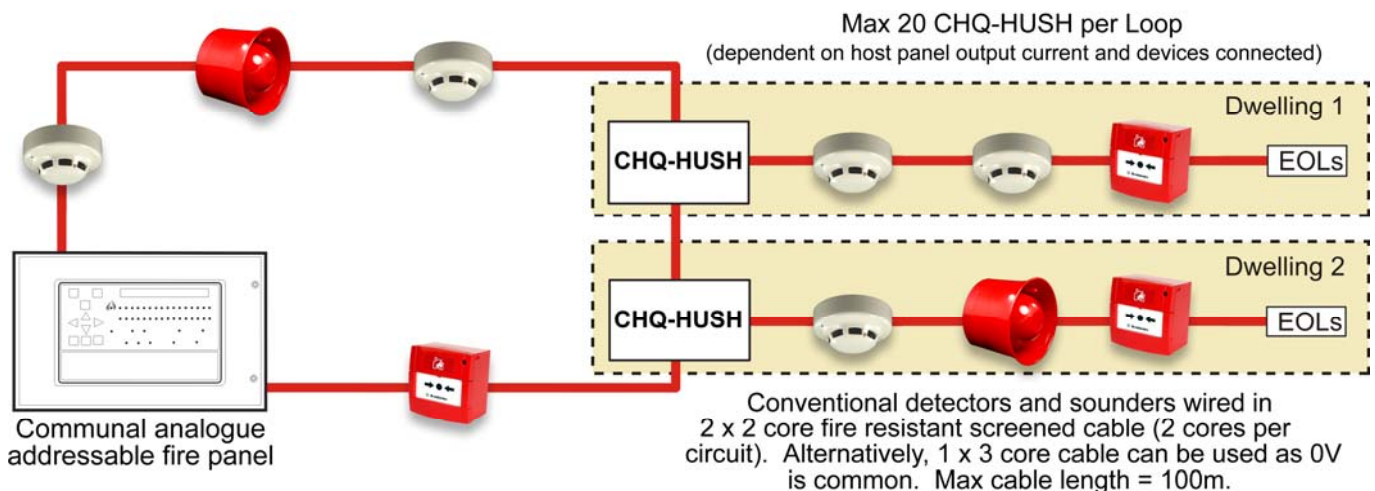

Key Features

- ❑ Upgrades the level of protection offered in a flat or apartment from the Grade D minimum (mains/battery smoke alarms) to Grade A or B
- ❑ Provides each individual dwelling with a 2 minute silence facility and 15 minute isolate facility to BS 5839 pt 6 clause 12.2
- ❑ Can be operated by building occupants whilst standing at floor level
- ❑ Includes a built-in loop isolator, conventional sounder circuit, conventional detector circuit and three status LEDs
- ❑ Fully monitored for open and short circuit faults (logging facilities at the host panel give full traceability of any problems)
- ❑ Failsafe operation - a general fire condition at the host panel will override any silenced/isolated state at the CHQ-HUSH and immediately turn on its local sounders
- ❑ Operation of a manual call point fitted with a resistor of less than 400 ohm will immediately trigger the host panel (a 330 Ohm resistor is supplied - see inside for wiring details)
- ❑ Common 0V line allows sounders and detectors to be wired in three core cable

System Design

Fire alarm system design is beyond the scope of this document. We recommend you read BS 5839 pt 6: 2004 (fire detection and fire alarm systems in dwellings), copies of which are available at your local reference library or from the BSI (www.bsi-global.com).

CHQ-HUSH WIRING

All wiring should be installed to meet the relevant requirements of BS 5839: Pt1: 2002, BS 5839: Pt6: 2004 and BS 7671 (Wiring Regulations).

For the CHQ-HUSH's conventional sounder and detector (zone) circuits, we recommend the use of 2 x two core fire resistant screened cable as shown, right. Alternatively, as 0V is common, three core fire resistant screened cable can be used.

Note: It is possible that a risk assessment and/or consultation with the relevant authorities may conclude that PVC cable is adequate for the detector and sounder circuits within the flat or apartment.

The host panel's analogue loop should always be wired in fire resistant screened cable. All wiring terminals will accept cables up to 1.5mm²

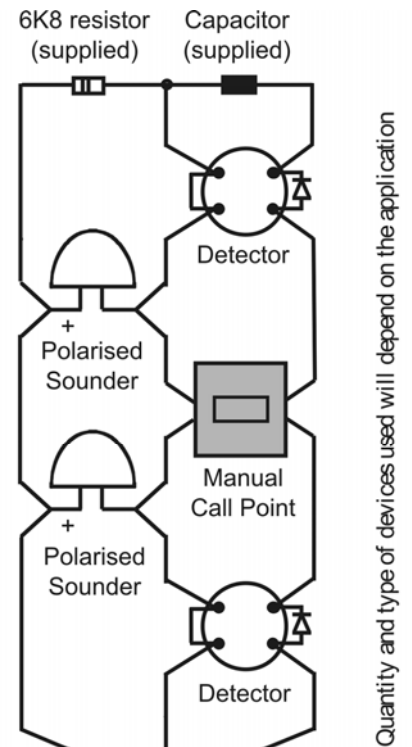

Setting the CHQ-HUSH Output Current

The CHQ-HUSH's output current should be set to 12.5mA, 20mA or 30mA to accommodate the total alarm current of all devices connected to its conventional sounder circuit. This is done by putting the PLK2 link in the appropriate position (see below). Always round the current up - for example, if two 7mA sounders are used, set the current to 20mA instead of 12.5mA.

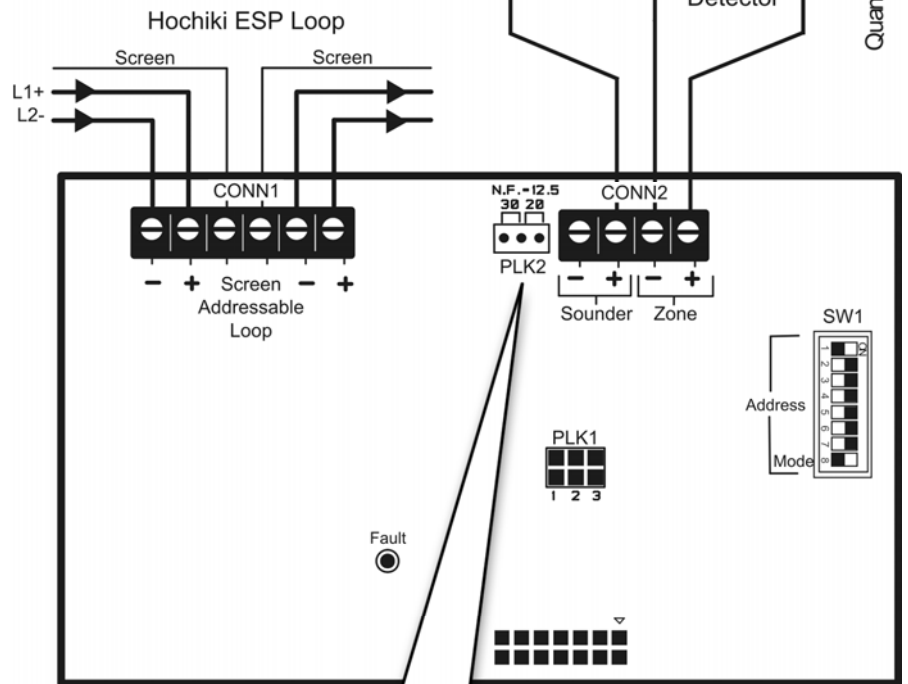

SET THE CHQ-HUSH OUTPUT CURRENT AS DETAILED LEFT AND BELOW

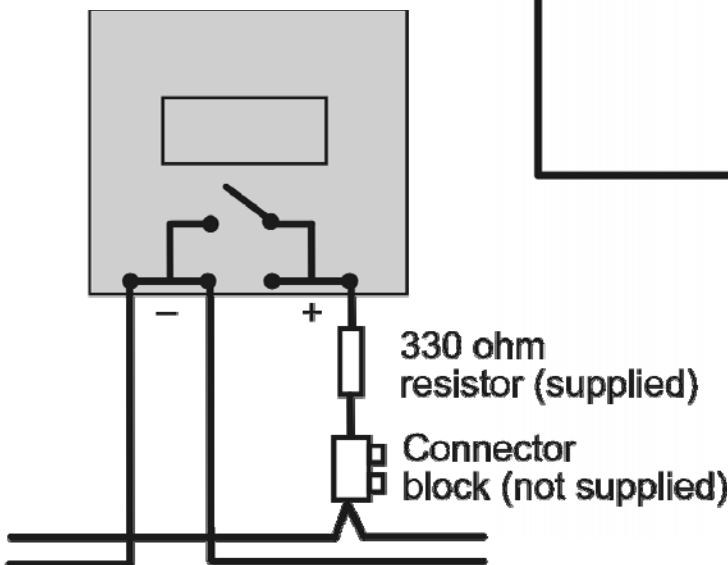

- = 12.5mA (no link fitted)
- = 20mA
- = 30mA

Connecting the provided 330 ohm resistor to a call point with a short circuit switch

Setting the CHQ-HUSH Address

To communicate and receive commands from the host fire panel, the CHQ-HUSH requires two addresses. The first allows it to be recognised as a 'Zone Monitor' and the second allows it to be recognised as a 'Wall Sounder'. Its 'Zone Monitor' address is set using the first seven segments of the 8-way DIL switch (SW1). A full list of addresses is shown below - set the switch to '0' or '1' as appropriate using a small screwdriver.

If segment 8 is in the default '0' position, the CHQ-HUSH's 'Wall Sounder' address will automatically be set to 127 above that chosen for its 'Zone Monitor' address. For example, if address 10 is selected for the 'Zone Monitor' address, then address 137 will be selected for the 'Wall Sounder' address and cannot be used for any other device on that loop.

Address	DIL position 1234567	Address	DIL position 1234567	Address	DIL position 1234567	Address	DIL position 1234567
1	1000000	33	1000010	65	1000001	97	1000011
2	0100000	34	0100010	66	0100001	98	0100011
3	1100000	35	1100010	67	1100001	99	1100011
4	0010000	36	0010010	68	0010001	100	0010011
5	1010000	37	1010010	69	1010001	101	1010011
6	0110000	38	0110010	70	0110001	102	0110011
7	1110000	39	1110010	71	1110001	103	1110011
8	0001000	40	0001010	72	0001001	104	0001011
9	1001000	41	1001010	73	1001001	105	1001011
10	0101000	42	0101010	74	0101001	106	0101011
11	1101000	43	1101010	75	1101001	107	1101011
12	0011000	44	0011010	76	0011001	108	0011011
13	1011000	45	1011010	77	1011001	109	1011011
14	0111000	46	0111010	78	0111001	110	0111011
15	1111000	47	1111010	79	1111001	111	1111011
16	0000100	48	0000110	80	0000101	112	0000111
17	1000100	49	1000110	81	1000101	113	1000111
18	0100100	50	0100110	82	0100101	114	0100111
19	1100100	51	1100110	83	1100101	115	1100111
20	0010100	52	0010110	84	0010101	116	0010111
21	1010100	53	1010110	85	1010101	117	1010111
22	0110100	54	0110110	86	0110101	118	0110111
23	1110100	55	1110110	87	1110101	119	1110111
24	0001100	56	0001110	88	0001101	120	0001111
25	1001100	57	1001110	89	1001101	121	1001111
26	0101100	58	0101110	90	0101101	122	0101111
27	1101100	59	1101110	91	1101101	123	1101111
28	0011100	60	0011110	92	0011101	124	0011111
29	1011100	61	1011110	93	1011101	125	1011111
30	0111100	62	0111110	94	0111101	126	0111111
31	1111100	63	1111110	95	1111101	127	1111111
32	0000010	64	0000001	96	0000011		

If the above method of addressing results in an "unrecognisable device" fault at the host panel, try setting segment 8 of the DIL switch to the '1' position. This will give the CHQ-HUSH a 'Wall Sounder' address one above that selected for its Zone Monitor address. For example, if address 15 is selected for the 'Zone Monitor', then address 16 will be selected for the 'Wall Sounder' address and cannot be used for any other device on that loop. Re-learn the loop as appropriate and check for correct operation. If you still encounter problems, contact your distributor for advice.

Operation

In its normal state (with no alarm conditions anywhere in the building), power is applied to the CHQ-HUSH's detector circuit, its detector and sounder circuits are continually monitored for faults, and its Supply Present LED is lit. In the event of a local alarm condition (when a fire detector within the flat or apartment has triggered), the CHQ-HUSH's local sounder circuit will activate and any output devices connected to it will sound.

If there is no one in the apartment to intervene during a local alarm condition (i.e. if the 'Hush' button is NOT pressed): The local alarm sounders will sound for a period of two minutes. If the local alarm clears within these two minutes, the CHQ-HUSH will return to its normal state. If the local alarm is still present after two minutes, the alarm will be signalled to the host analogue fire panel and a general alarm condition will be enunciated around the building as programmed.

If the 'Hush' button is pressed DURING a local alarm condition: A hushed period of two minutes will commence starting from when the CHQ-HUSH is pressed. If the local alarm is cleared within these two minutes, the CHQ-HUSH will return to its normal state. If the alarm doesn't clear, 15 seconds before the hushed period is about to expire, a beeper will sound to inform the occupant that the alarm is about to be signalled to the host fire panel. If the 'Hush' button is pressed again during this 15 second period, another two minute hushed period will commence.

If the 'Hush' button is pressed when there are no alarms present: A hushed period of fifteen minutes will commence. During this period, power is cut to the local zone so no alarm signals from detectors will be detected (however a manual call point with a suitable resistor, less than 400 ohms, will trigger a full alarm if activated). If the 'Hush' button is pressed again during this 15 minute period, power is re-applied to the local zone allowing normal signal processing to resume. 15 seconds before the 15 minute hushed period is about to expire, a beeper will sound to inform the occupant that the local zone is about to be re-powered. If the 'Hush' button is pressed again during this 15 second period, another 15 minute hushed period will commence.

Manual Call Points

If a manual call point is connected to the CHQ-HUSH's detector circuit, provided its resistance when operated is less than 400 ohms, its operation will immediately trigger the CHQ-HUSH's sounder circuit and signal a general alarm condition to the host fire panel.

General Fire Conditions

If, at any time, the host analogue panel enters a general fire condition, it overrides any hushed state at the CHQ-HUSH and turns on its local sounders. Pressing the 'Hush' button in a general fire alarm condition **WILL NOT** silence the local alarm sounders and the dwelling should be evacuated as per the designated fire management plan.

XFP508H TECHNICAL SPECIFICATION

Compatible protocol	Hochiki ESP
Max. no of CHQ-HUSHs per analogue loop:	20 (dependent on output current of host panel and CHQ-HUSH)
Onboard loop isolator:	Yes
Max. conventional detectors per CHQ-HUSH:	10
Max. manual call points per CHQ-HUSH:	10 (must be fitted with a resistor of less than 400 Ohms)
Max. sounder circuit load per CHQ-HUSH:	30mA:
Operating voltage	22-40Vdc
Quiescent current:	5mA
Max. length of detector and sounder circuits:	100m
User indicators:	Green 'Supply present' LED: Lit steady when the unit is powered up
	Red 'Local alarm' LED: Lit steady when a detector is in alarm
	Yellow 'Hushed' LED: Lit steady when the unit is in the Hushed state. Flashes during the last 15 seconds of any Hushed period.
	Beeper: Gives audible feedback when the CHQ-HUSH is pressed and also sounds during the last 15 seconds of any Hushed period.
Engineer Indicators:	Fault LED (yellow): Lit steady when there is an open or short on the detector or sounder circuit.
User controls:	1 x HUSH button - see 'Operation' section for details
Engineer controls:	PLK2: Output current selector, 12.5mA; 20mA or 30mA (link adjustable) <input type="checkbox"/>
Dimensions:	144mm x 84mm x 37mm. Mounts on a 25mm UK double gang back box



Hochiki Europe (UK) Ltd
 Grosvenor Road, Gillingham Business Park,
 Gillingham, Kent, ME8 0SA, England
 Telephone: +44(0)1634 260133 Facsimile: +44(0)1634 260132
 Email: sales@hochikieurope.com
 Web: www.hochikieurope.com

Hochiki Europe (UK) Ltd. reserves the right to alter the specification of its products from time to time without notice. Although every effort has been made to ensure the accuracy of the information contained within this document it is not warranted or represented by Hochiki Europe (UK) Ltd. to be a complete and up-to-date description. Please check our web site for the latest version of this document.