

Hochiki CHQ-BS Installation Instructions



Product Covered :CHQ-BS installed with ALG-E,ALG-E(NP)/AIE-E,AIE-E(NP)/ATG-E,ATG-E(NP)/ACA-E

Introduction

The Loop Powered Sounder (CHQ-BS) is designed to replace the standard common mounting base (YBN-R/3) and the isolator base (YBO-R/SCI) in locations where Loop Powered Sounders are required. The CHQ-BS has the same connections as the YBN-R/3 and YBO-R/SCI and hence can easily be retrofitted if required. The CHQ-BS is designed to give audibility in locations such as Hotel Bedrooms, Offices and Corridors.

Address Setting

The default address of the CHQ-BS is 254, and therefore if the CHQ-BS is to be used as a base sounder (sensor on top) then the address will not need to be changed, as the control panel will automatically address the sounder as described below. However, if the sounder is to be used as a wall sounder then the CHQ-BS will need to be manually addressed between 1 and 127 as described below. **Note: Control Panel compatibility needs to be checked to verify if automatic addressing above 127 is supported.**

1. Automatic addressing (Control Panel)

The control panel automatically assigns the address to the base sounder at initialisation, the address is calculated by taking the address of the sensor that is fitted to the base sounder and adding 127, this is then stored within the base sounder. i.e. if a sensor is set at address 10 then the base sounder would be automatically set at address 137 (Addresses above 127 may not be visible to the user depending upon the implementation by the Control Panel).

2. Manual Addressing (Hand held programmer)

The base sounder address can be set using the Hand Held programmer (TCH-B100) between 1 and 254. See the instructions for the address programmer TCH-B100 about detail of setting method. If the CHQ-BS is to be used as a wall sounder then the address should be programmed between 1 and 127 before being installed, if the CHQ-BS is to be configured as a base sounder (sensor on top) then the address needs to be programmed between 128 and 254.

Tones and volumes

Table 1 below shows the full range of sound outputs available from the CHQ-BS and the amount of current drawn when operated, when the CHQ-BS is selected to be a base sounder (sensor on top) then the default sound output will be 85dB. The CHQ-BS is also capable of utilising a number of different tones these are listed in table 2. **The tone of the sounder and the volume level is selected and controlled by the control panel, therefore check with the control panel manufacturer for options and default values available.**

Table 1

Current Drawn	Sound Output dB (A)
0.8 mA	70 dB
1.5 mA	78 dB
2.0 mA	80 dB
3.0 mA	85 dB
4.5 mA	88 dB
6.5 mA	90 dB
8.0 mA	93 dB
10 mA	94 dB
11 mA	95 dB

Table 2

Tone Number	Tone & Frequency
1	925Hz/628Hz @ 2Hz
2	925Hz Continuous
3	628Hz Continuous
4	French 554Hz 100ms/440Hz 400ms
5	Swedish 660Hz 150ms on 150ms off
6	925Hz 150ms on 600ms off
7	670Hz 250ms/845Hz 375 ms

Precautions

- Ensure that the base sounder is installed in accordance with Local Standards or Regulations.
- Check that the sensor is compatible with the base sounder type.
- Only install in suitable environments, the following in particular should be avoided:-
 - Excessive ambient temperature.
 - Where excessive condensation or moisture is present.
 - Hazardous areas.
- A high voltage tester must not be used with this base sounder
- Ensure that the base sounder is securely fixed to the ceiling or other suitable surface.

- ❑ Ensure that the base sounder terminals are securely fastened.
- ❑ For proper wiring supervision ensure that the cables are routed as shown in the diagram overleaf.

Installation

The base sounder comes with an adapter plate which allows connection to standard Besa back boxes, this mounting plate must be mounted on the surface that the sounder is to be fitted. The adapter plate should be removed from the bottom of the sounder and the connection cable passed through the centre hole, the adapter plate should be mounted using countersunk style screws. The connection cables can then be passed through the base sounder and the sounder screwed to the adapter plate with the two M3 screws supplied. The cables then can be connected as per wiring diagram below;

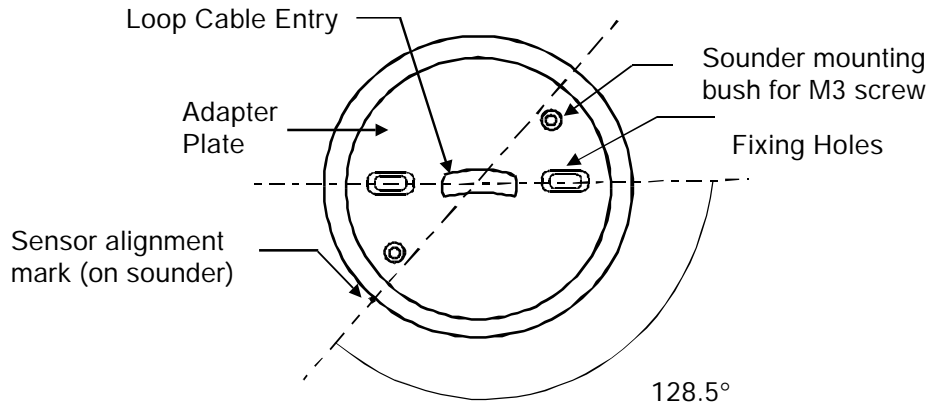

Fitting cap for wall Sounder

A push fit cap to cover the electrical connection is available (S/I-BC) if an analogue sensor is not being fitted, the alignment arrow inside the cap which has no text should be aligned with the sensor alignment mark on the base sounder. This will align the four tabs on the cover with the matching slots in the base sounder, once this has been achieved then the cap is pushed until a click is heard.

Wiring

The wiring diagram for the base sounder should be made as shown.

- A: Loop (+)
- B: Loop (-)
- C: Cable Screen

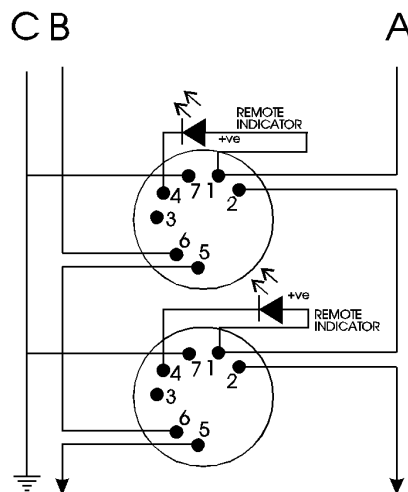

Hochiki Europe (UK) Limited, Grosvenor Road,
 Gillingham Business Park, Gillingham, Kent, ME8 0SA.
 Telephone: 01634 260 133 Facsimile: 01634 260 132
 E-mail: sales@hochikieurope.co.uk