

Model SBB-1 Surface Back Box

APPLICATION NOTE

Benefits in using the SBB-1 Back Box in place of standard BESA box

This Application Note covers the Hochiki SBB-1 Surface Back Box and how it can be utilised within certain installations.

The approved design of the SBB-1 provides a splash-proof and secure fixing for the Hochiki CDX and ESP Range of Detectors and Sensors, and their associated Bases. It can be installed on a variety of different fixing surfaces and because it has been manufactured to match the colour of Hochiki's range of products, it provides an aesthetically pleasing solution where surface fixed devices are required.

The housing supports three 20mm glanded entries, for zone, or loop cabling access (glands not included) and is supplied with base fixing screws.

The detector base fits directly onto the SBB-1 and sits within a slight recess. This provides the accurate fit and the protection against dust and water ingress.

Compatible Hochiki Products:

YBN-R/4
YBN-R/4SK
YBN-R/4(IS)
YBO-R/5
YBO-R/5SK
YBO-R/5ZD
YBO-R/5PA
YBO-R/12V
YBN-R/3

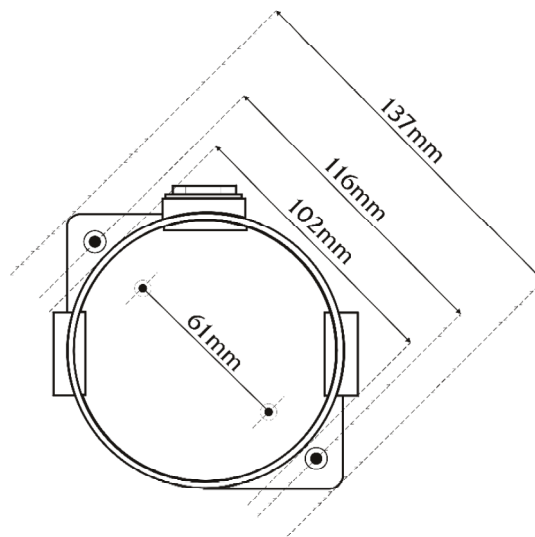

The SBB-1 provides a sturdy fixing for smoke and heat detectors and sensors whilst appearing compact and unobtrusive compared to a standard BESA back box.

Using a standard BESA style box means that a ledge is created when the detector and base are fitted to the underside. In some applications this ledge can be unacceptable according to certain Health & Safety standards regarding dust in food preparation or storage areas.

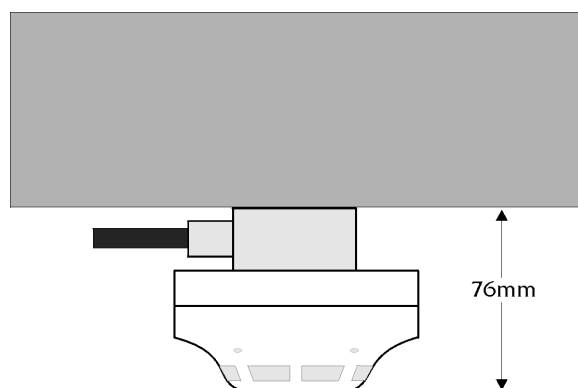

CONVENTIONAL PHOTO-ELECTRIC
SMOKE DETECTOR SLR-EM
with
YBN-R/4M BASE
mounted on
STANDARD BESA BOX

Using the SBB-1 back box eliminates this problem by providing a flush mounting manufactured to exactly fit the Hochiki range of bases with no additional height.

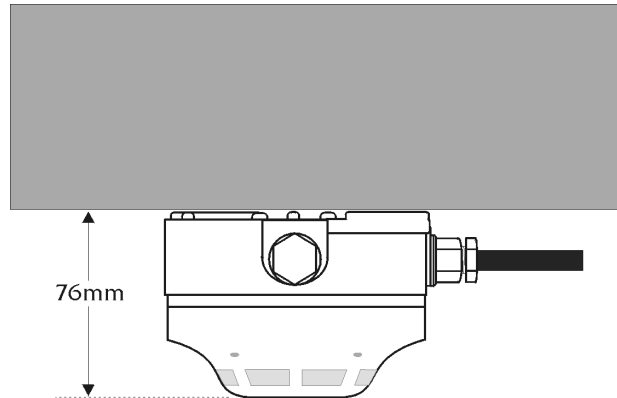

CONVENTIONAL PHOTO-ELECTRIC
SMOKE DETECTOR SLR-E
with
YBN-R/4 BASE
mounted on
SBB-1 Surface Mounting Back Box

NOTE: This Application Note is applicable only to the Hochiki range of detectors and bases.



Hochiki Europe (UK) Ltd
Grosvenor Road, Gillingham Business Park,
Gillingham, Kent, ME8 0SA, England
Telephone: +44(0)1634 260133 Facsimile: +44(0)1634 260132
Email: sales@hochikieurope.com
Web: www.hochikieurope.com

Hochiki Europe (UK) Ltd. reserves the right to alter the specification of its products from time to time without notice. Although every effort has been made to ensure the accuracy of the information contained within this document it is not warranted or represented by Hochiki Europe (UK) Ltd. to be a complete and up-to-date description. Please check our web site for the latest version of this document.