

APPLICATION NOTE

Document Title Interfacing SPB-E Beam Detectors

Date August 2000

Version AP024/ISS 1

APPLICATION NOTE

INTERFACING SPB-E BEAM DETECTORS

Hochiki's optical beam smoke detector (SPB-E) operates from a conventional zone but can be interfaced on to an addressable system via a switch or zone monitor. It is supplied complete with an installation kit that gives the user various options for easy installation onto conventional and addressable systems. The installation kit is mounted on a standard M.K back box which can be surfaced or flush mounted, the field connections are via a two part connector which allows the installer to make all connections without risk to the PCB. The commissioning engineer can install the PCB and select the type of line continuity that is required.

Product Features

- The SPB-E is mounted on a standard M.K back box (41 mm deep).
- Supplied with an interface kit for easy installation.
- Installation kit is fitted with a 470 ohm fire resistor.
- Both zener, schottky diode and open circuit options are selectable.
- The SPB-E is automatically reset from the zone.

Interfacing the SPB-E onto Hochiki's ESP protocol

This is undertaken by using Hochiki's Dual Zone Monitor (CHQ-Z) as shown below.

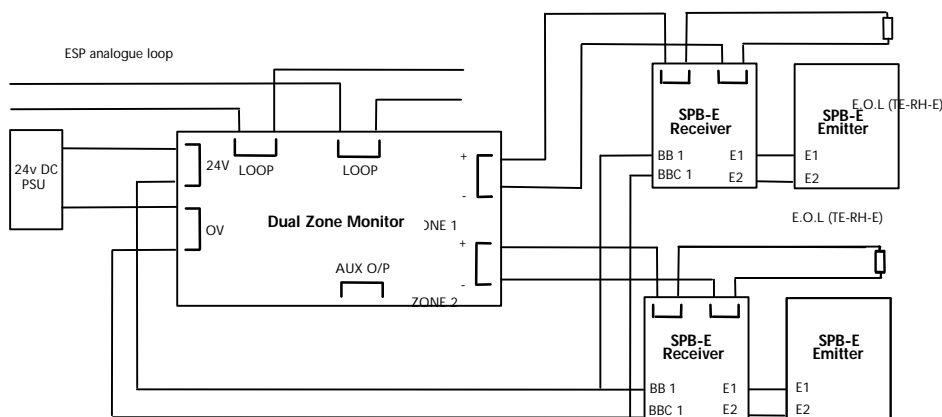

Fig.1

Notes

For the above configuration the link settings on the interface kit must be in the open circuit mode (jumpers JP2, JP5 and JP6 are all made, all other jumpers are removed).

PSU Requirement.

Both the CHQ-Z and the SPB-E require an auxiliary 24v DC power supply the table below shows the current drawn in normal and fire condition.

Product	CONDITION	
	Normal	Fire
SPB-E	200 μ A	20 mA
CHQ-Z	800 μ A	35 mA for each zone

Interfacing the SPB-E onto a third party analogue addressable system

The SPB-E can be interfaced on to a third party analogue system in two ways. The zone monitor is the preferred solution when interfacing, as it uses the standard interface kit which provides line continuity options and power supply monitoring. The second method is via a switch monitor, this method is needed as some third party systems are limited to the number of zone monitors on the loop, or if the third party cannot support zone monitors.

1. Zone Monitor

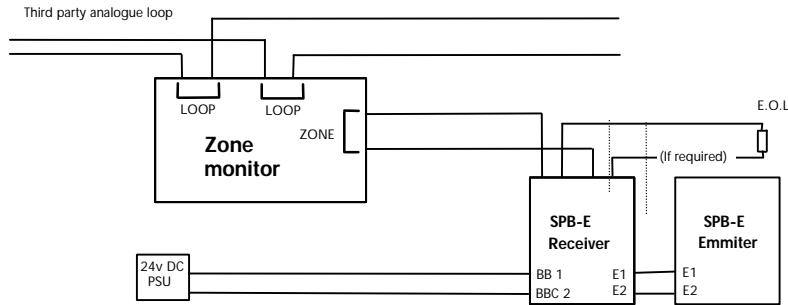

E.O.L. = To manufactures specification

When the above method is being used the third party conventional zone monitor must be capable of generating a fire condition when 470 ohms is placed across the zone, to ensure the SPB-E enters the fire condition and resets correctly the zone monitor must be capable of the following specifications.

CONDITION	VOLTS
Zone voltage range	18v-30v
Min. zone voltage with 470 ohm across the zone (Alarm)	5v
Zone voltage at reset	0v

2. Switch Monitor

The SPB-E can be interfaced onto a third party addressable system with the use of a switch monitor. For this operation the SPB-E should be mounted using the interface kit front mounting plate and ribbon cables (the PCB should not be used). The relay across the 24v is used for the monitoring of the power supply, the normally closed contacts will operate if the beam detector power supply is removed and hence a fault condition will be signalled. The receiver fault relay is normally open and will not change state when the power is removed.

