

APPLICATION NOTE

Document Title Addressable Input/Output Module (AMU-C2)

Date August 2000

Version APP013/ISS 2

APPLICATION NOTE

Addressable Input / Output Module (AMU-C2)

The AMU-C2 is a universal input/output device, which may be arranged to control either sounders via the integral, fully monitored sounder output, or plant shutdown if used as a voltage free contact. A second output is available to control other devices via a suitable interface circuit. An input is available to monitor a normally open contact which could be used to monitor plant alarms etc.

Product Features

- The AMU-C2 contains two individual outputs and one input for transmission back to the control panel.
- Full monitoring against malfunction or disconnection ensures integrity of the unit at all times. The main output (output 1) and the auxiliary power supply can be monitored for open or short circuit.
- The input monitors a normally open contact. This input, made across DA and DAC can be arranged to show device fault on the control panel. (Subject to control panel capability)
- The main output (output 1) may be used as a voltage free change over contact (polarised) capable of switching up to 1A. No auxiliary power supply unit is required but no monitoring is available. With the addition of an auxiliary power supply unit, upto 1A of sounders can be controlled and they are monitored for open or short circuits.
- The auxiliary output (output 2) is an open collector transistor type and may be used to control small loads or to interface with some form of additional circuitry, eg:- an oscillator, for generating an alert control on the main output sounders.

Installations / Connections

If the main output (output 1) is required to operate sounders, the sounders must be polarised and a 30v-40v variable resistor (VDR) must be fitted across the sounder lines B and BC. The 24v auxiliary power supply must be connected to the BB (+) and the BBC (-) leads, and fused at 1.5A. Please refer to connection diagram below.

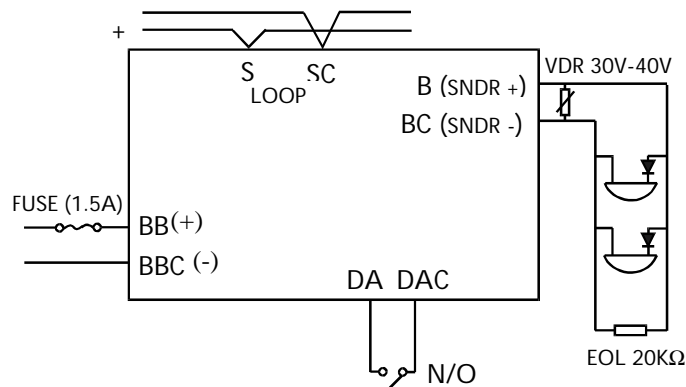

If the main output (output 1) is to be used as a voltage free (polarised) output then please refer to the connection diagram below.

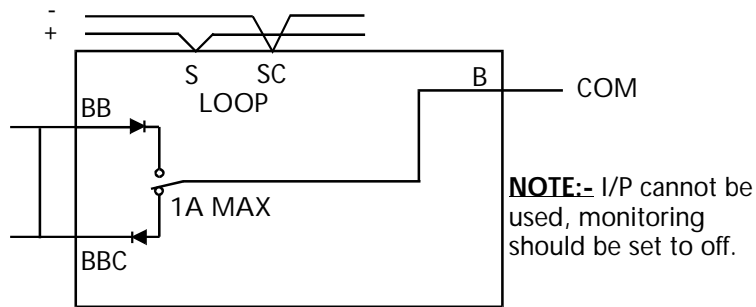

The auxiliary output (output 2) is an electronic output and must be used with care to avoid damage to the AMU-C2. Please refer to the connection diagram below.

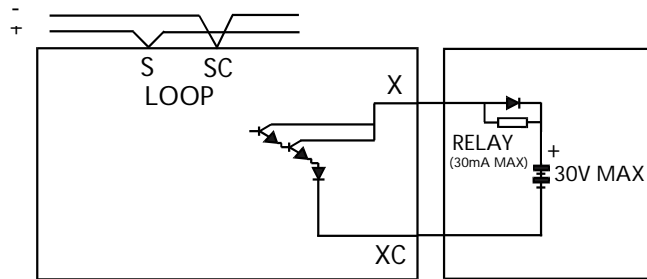

The monitoring of the main output (output 1) for a wiring fault and the power supply input monitoring may be disabled using bit 8 of the 8 bit DIL switch (as shown below). In this condition input DA/DAC cannot be used.

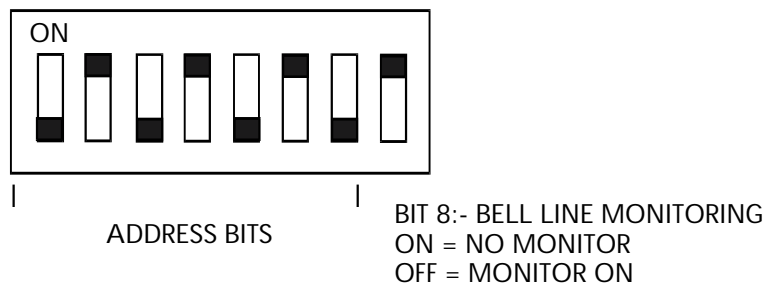

Switch location and operation

The DIL switch is located on the AMU-C2 PCB in the position shown below. The PCB is exposed by removing the two self tapping screws in the cover. The bits of the switches should be operated carefully with a small screwdriver.

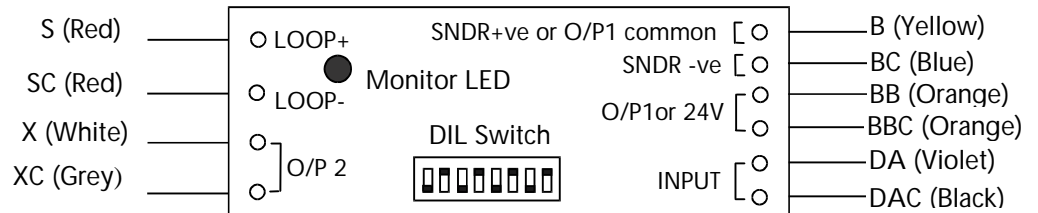

Hochiki Europe (UK) Ltd
Grosvenor Road, Gillingham Business Park,
Gillingham, Kent, ME8 0SA, England
Telephone: +44(0)1634 260133 Facsimile: +44(0)1634 260132
Email: sales@hochikieurope.com
Web: www.hochikieurope.com

Hochiki Europe (UK) Ltd. reserves the right to alter the specification of its products from time to time without notice. Although every effort has been made to ensure the accuracy of the information contained within this document it is not warranted or represented by Hochiki Europe (UK) Ltd. to be a complete and up-to-date description. Please check our web site for the latest version of this document.